

SH
SKH

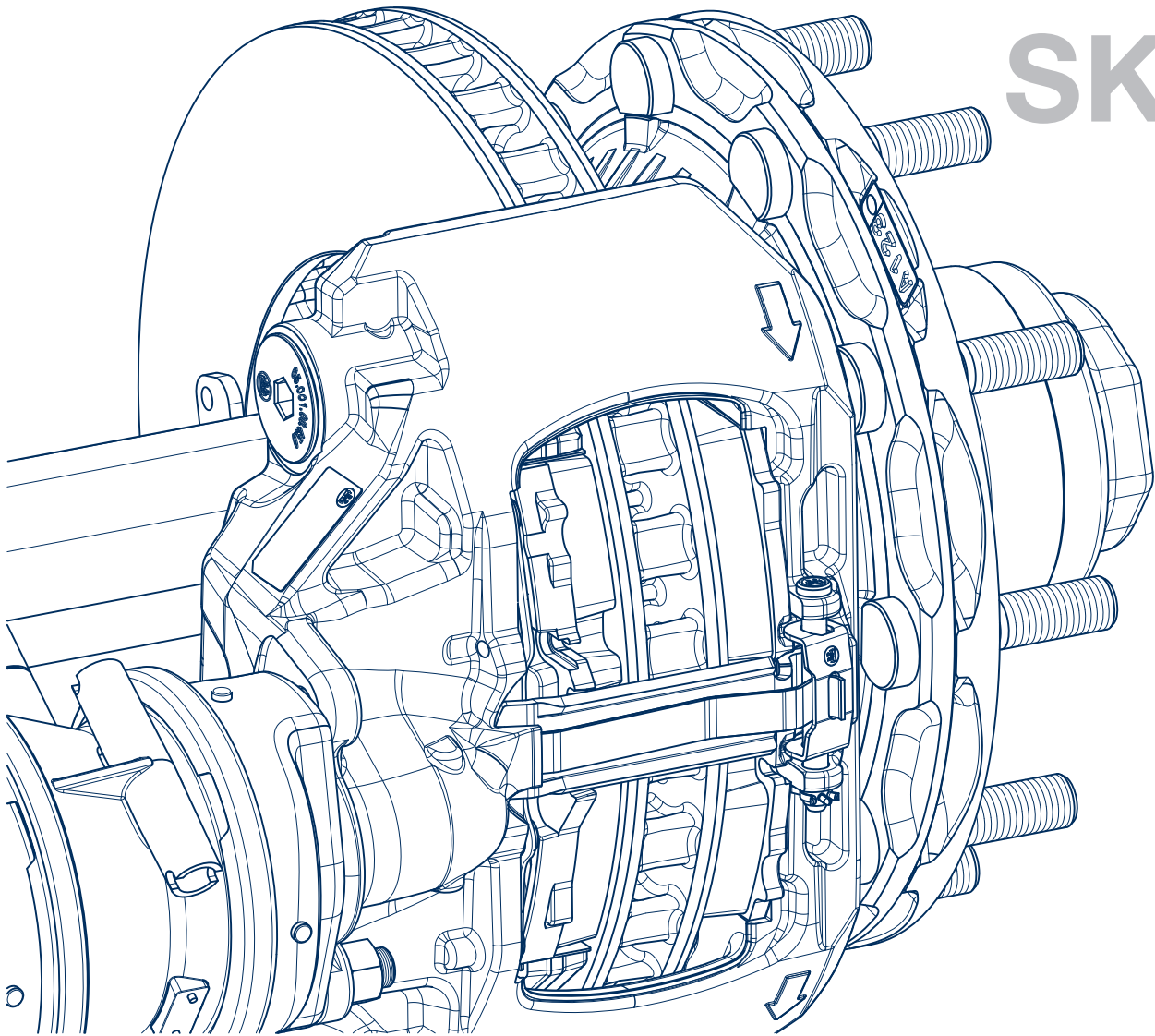

ECO Disc TSB / TS2 Werkzeug-Koffer

ECO Disc TSB / TS2 tool case

Mallette outils ECO Disc TSB / TS2

99.00.000.9.76



1. Auflage / edition / édition 15.02.2024

Änderungen vorbehalten. Aktuelle Version, sowie weiteres Informationsmaterial, finden Sie auf unserer Internetseite unter www.bpw.de

Subject to change without notice.

Current versions and additional information can be found online at www.bpw.de.

Sous réserve de modifications.

Vous trouverez les versions actuelles, ainsi que d'autres documents d'information, sur notre site Internet à l'adresse suivante : www.bpw.de.

-
- ⊙ **Die Spezialwerkzeuge gewährleisten eine sichere und einfache Durchführung aller empfohlenen Servicearbeiten an der BPW ECO Disc (TSB 3709 / 4309 / 4312 und TS2 3709 / 4309).**
 - ⊙ **Alle Arbeiten am Fahrzeug dürfen nur von Mitarbeitern der Nutzfahrzeug-Industrie und des Nutzfahrzeug-Handwerks mit der entsprechenden Fachkompetenz durchgeführt werden. Es sind stets die Sicherheitsanweisungen des Fahrzeugherstellers beachten.**
 - ⊙ **Bitte beachten Sie das BPW Werkstatthandbuch (www.bpw.de).**
-
- ⊙ **The special tools ensure that all recommended service work on the BPW ECO Disc (TSB 3709 / 4309 / 4312 and TS2 3709 / 4309) can be performed safely and easily.**
 - ⊙ **Only employees in the commercial vehicle industry and trade who have the appropriate technical proficiency are permitted to perform work on the vehicle.**
 - ⊙ **Please refer to the BPW workshop manual (www.bpw.de).**
-
- ⊙ **L'outillage spécial garantit une exécution fiable et simple de tous les travaux d'entretien recommandés pour l'ECO Disc BPW de type TSB 3709 / 4309 / 4312 et TS2 3709 / 4309.**
 - ⊙ **L'exécution de tous les travaux sur le véhicule est exclusivement réservée au personnel de l'industrie et de la profession des véhicules utilitaires disposant de la qualification correspondante. Toujours respecter les instructions de sécurité du constructeur du véhicule.**
 - ⊙ **Prière de respecter le manuel de réparation BPW (www.bpw.de).**
-

Übersicht / Overview / Aperçu

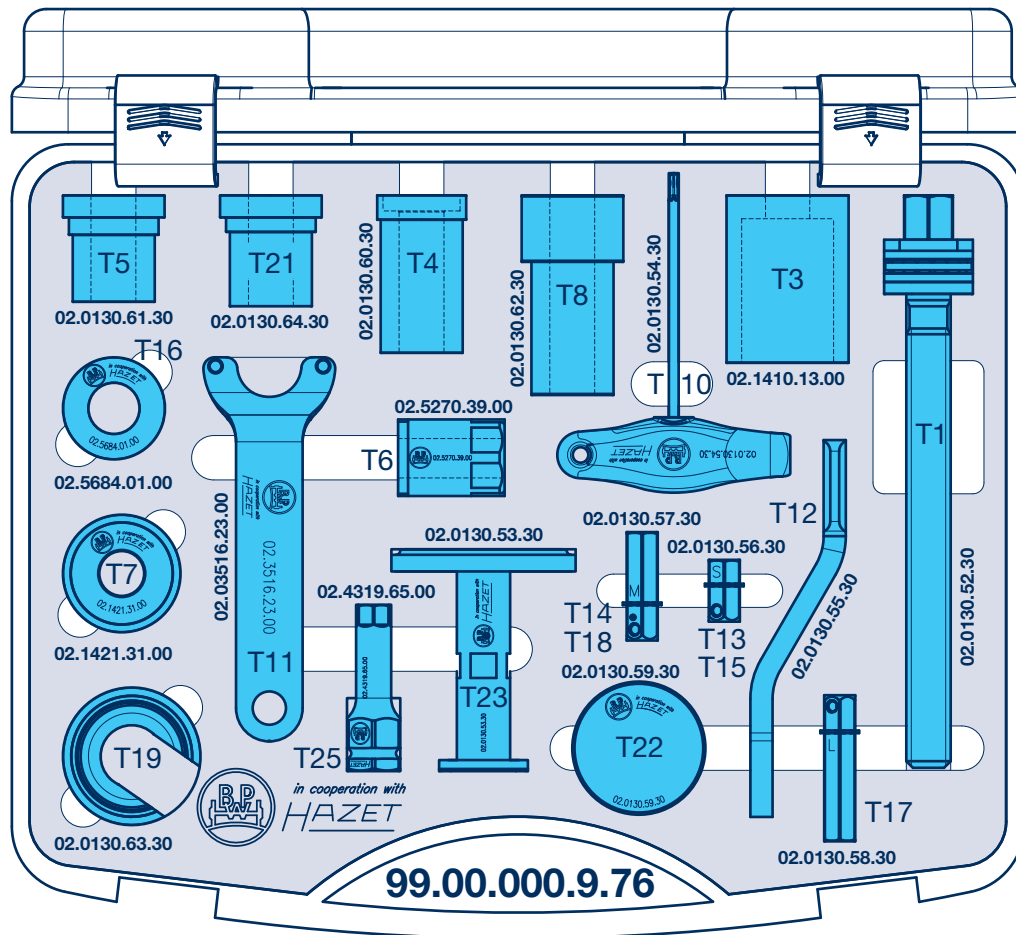

Anordnung im Koffer / Tool case arrangement / Répartition dans la mallette

Nr. / No. / N°	Benennung / Name / Désignation	TSB	TS2	BPW Sachnummer / BPW code number / Référence BPW
T1	Gewindespindel / Threaded spindle / Broche fileté	⊙	⊙	02.0130.52.30
T2	- -			
T3	Ausziehhülse / Extractor sleeve / Douille d'extraction	⊙	⊙	02.1410.13.00
T4	Auspresswerkzeug Los- und Festlager / Press-out tool for movable and fixed bearings / Extracteur de palier libre et fixe	⊙	⊙	02.0130.60.30
T5	Einpresswerkzeug Loslager / Pressing tool (movable bearing) / Outil d'emmanchement (palier libre)	⊙		02.0130.61.30
T6	Spindelmutter / Spindle nut / Écrou de la tige	⊙	⊙	02.5270.39.00
T7/T20	Gegenhalter / Counter-hold tool / Contre-support	⊙	⊙	02.1421.31.00

Übersicht / Overview / Aperçu

Nr. / No. / N°	Benennung / Name / Désignation	TSB	TS2	BPW Sachnummer / BPW code number / Référence BPW
T8	Einpresswerkzeug Festlager / Pressing tool (fixed bearing) / Outil d'emmanchement (palier fixe)	⊙	⊙	02.0130.62.30
T9	- -			
T10	Torxschlüssel Rückstellung / Torx spanner return mechanism / Clé Torx (remise à zéro)	⊙		02.0130.54.30
T11	Zweilochschlüssel für Grobschmutz-Dichtung / Two-hole spanner for coarse dirt seal / Clé à deux ergots pour joint anti-salissures grossières	⊙		02.3516.23.00
T12	Schlagschlüssel / Impact spanner / Clé à chocs	⊙	⊙	02.0130.55.30
T13	Klinge für Schlagschlüssel - Größe S / Blade for impact spanner - size S / Lame pour clé à chocs - Taille S	⊙	⊙	02.0130.56.30
T14	Klinge für Schlagschlüssel - Größe M / Blade for impact spanner - size M / Lame pour clé à chocs - Taille M	⊙	⊙	02.0130.57.30
T15	Klinge für Schlagschlüssel - Größe S / Blade for impact spanner - size S / Lame pour clé à chocs - Taille S	⊙	⊙	02.0130.56.30
T16	Ring zum Einziehen der Radbolzen / Ring for pulling in wheel studs / Bague pour mise en place des goujons de roue	⊙	⊙	02.5684.01.00
T17	Klinge für Schlagschlüssel - Größe L / Blade for impact spanner - size L / Lame pour clé à chocs - Taille L	⊙	⊙	02.0130.58.30
T18	Klinge für Schlagschlüssel - Größe M / Blade for impact spanner - size M / Lame pour clé à chocs - Taille M	⊙	⊙	02.0130.57.30
T19	Montagewerkzeug für Faltenbalg / Mounting tool for the bellows / Outil de montage pour soufflet	⊙		02.0130.63.30
T21	Einpresswerkzeug Loslager / Pressing tool for loose bearing / Outil d'emmanchement (palier libre)		⊙	02.0130.64.30
T22	Glocke für Einpresswerkzeug Faltenbalg / Piston for pressing tool bellows / Piston pour outil d'emmanchement pour soufflet		⊙	02.0130.59.30
T23	Einpresswerkzeug / Pressing tool / Outil d'emmanchement		⊙	02.0130.53.30
T24	- -			
T25	Schlag- und Maschinenschraubereinsatz Impact and machine screwdriver insert Visseuse à percussion et visseuse mécanique	⊙	⊙	02.4319.65.00

Die Bezeichnungen T1 - T25 dienen der einfacheren Zuordnung und sind nicht im Werkzeugkoffer vermerkt.

The designations T1 - T25 are used for easier categorisation and are not noted in the tool case.

Les désignations T1 - T25 servent à faciliter le classement et ne sont pas indiquées dans la boîte à outils.

Spezialwerkzeuge / Special tools / Outil spécial

T1

Gewindespindel inkl. Kugellager /
Threaded spindle incl. ball bearing
Broche filetée avec roulement à billes

02.0130.52.30 TR 20 x 3 / SW 22

Max. Anziehdrehmoment: 300 Nm
Keinen Schlagschrauber verwenden!

Max. Tightening torque: 300 Nm
Do not use an impact wrench!

Couple de serrage max. : 300 Nm
Ne pas utiliser de visseuse à choc !

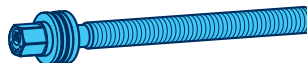
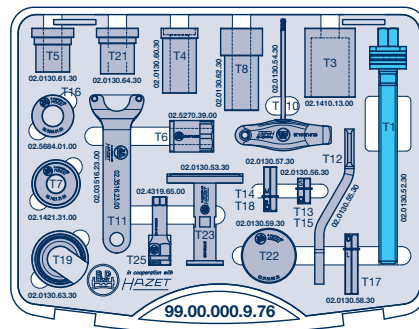

T3

Ausziehülse /
Extractor sleeve /
Douille d'extraction

02.1410.13.10 Ø 20,2 / 42 x 75,5

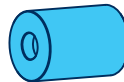
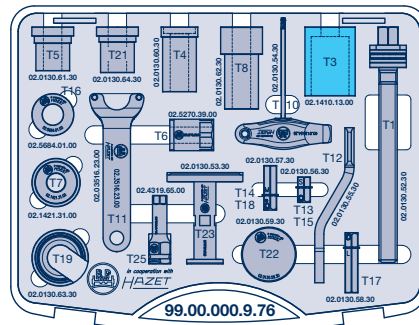

T4

Auspresswerkzeug Los- und Festlager /
Press-out for moveable and fixed
bearings /
Extracteur de palier libre et fixe

02.0130.60.30 Ø 20,5 / 40,1 x 71

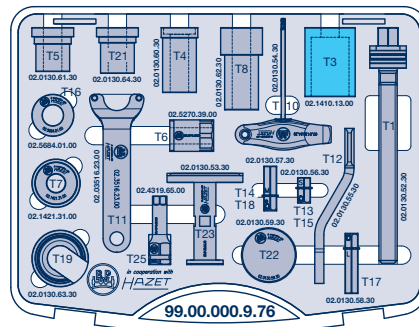

T5 (TSB)

Einpresswerkzeug Loslager /
Pressing tool (moveable bearing) /
Outil d'emmanchement (palier libre)

02.0130.61.30 Ø 20,5 / 45,8 x 48

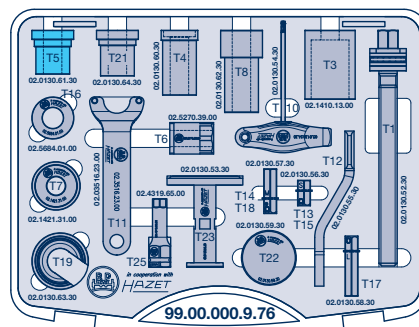

Anwendung siehe Seite 12 - 15 /
Application see page 12 - 15 /
Application voir page 12 - 15

Spezialwerkzeuge / Special tools / Outil spécial

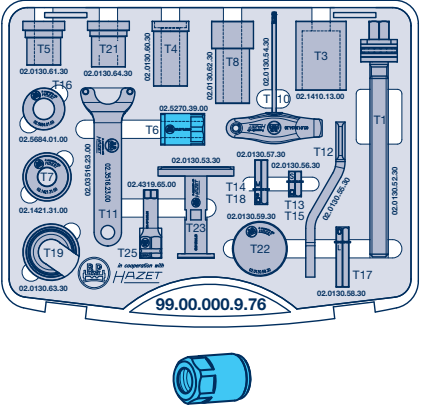
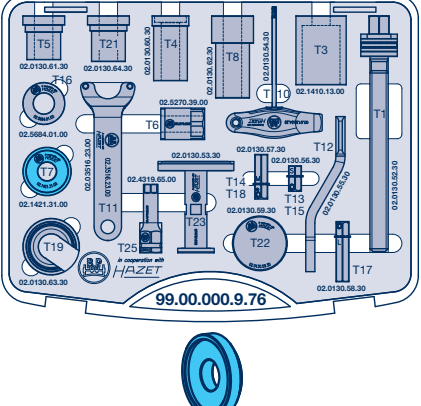
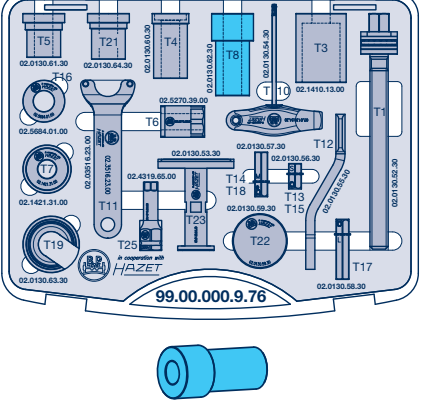
<p>T6</p> <p>Spindelmutter / Spindle nut / Écrou de la tige</p> <p>02.5270.39.00 TR 20 X 3 / SW 32</p>		
<p>T7/T20</p> <p>Gegenhalter / Counter-hold tool / Contre-support</p> <p>02.1421.31.00 Ø 20,2 / 53 x 13</p>		
<p>T8</p> <p>Einpresswerkzeug (Festlager) / Pressing tool (fixed bearing) / Outil d'emmanchement (palier fixe)</p> <p>02.0130.62.30 Ø 20,5 / 45,8 x 90</p>		<p>Anwendung siehe Seite 12 - 15 / Application see page 12 - 15 / Application voir page 12 - 15</p>

Spezialwerkzeuge / Special tools / Outil spécial

T10 (TSB)

Torxschlüssel für die Rückstellung /
Torx spanner return mechanism /
Clé Torx (remise à zéro)

02.0130.54.30 TX 25

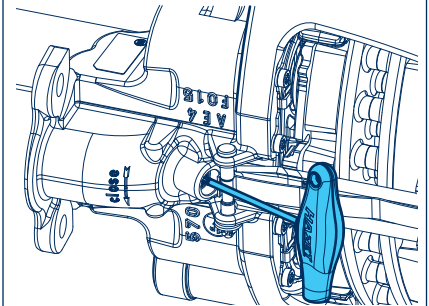
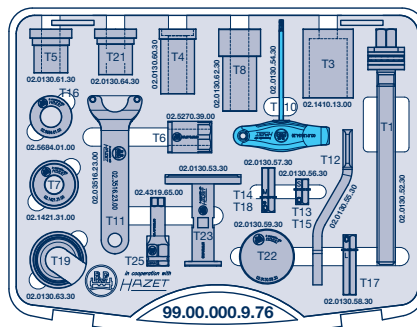

T11 (TSB)

Zweilochschlüssel für
Grobschmutz-Dichtung /
Two-hole spanner for coars dirt seal /
Clé à deux ergots pour joint anti-
salissures grossières

02.3516.23.00 L = 173

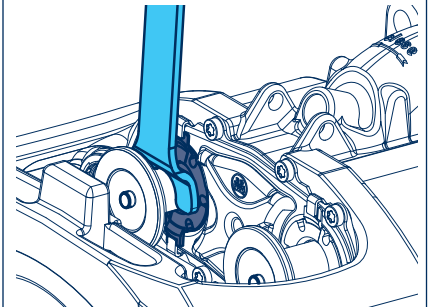
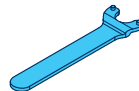
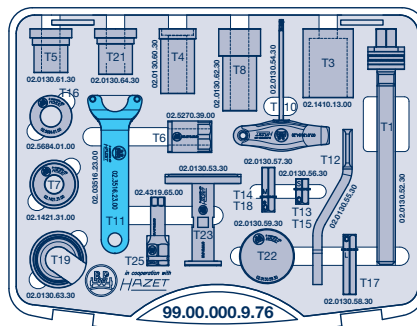

T12

Schlagschlüssel /
Impact spanner /
Clé à chocs

02.0130.55.30 SW 14

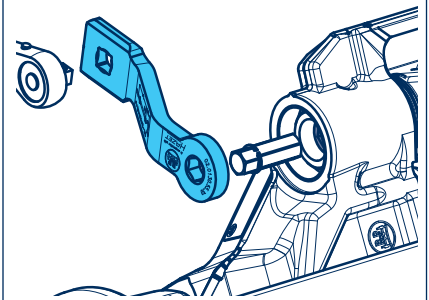
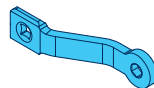
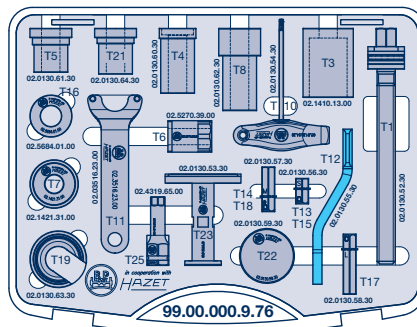

T13 / T15

Klinge für Schlagschlüssel - Größe S /
Blade for impact spanner - size S /
Lame pour clé à chocs - Taille S

02.0130.56.30 SW 14 / L = 27,9

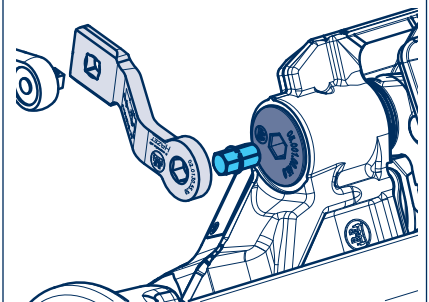
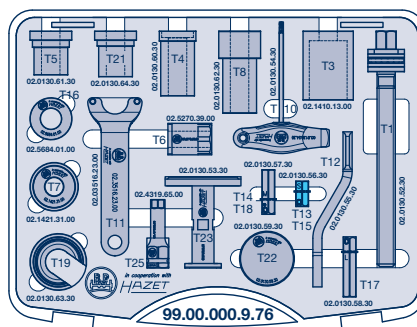

Spezialwerkzeuge / Special tools / Outil spécial

T14 / T 18

Klinge für Schlagschlüssel - Größe M /
Blade for impact spanner - size M /
Lame pour clé à chocs - Taille M

02.0130.57.30 SW 14 / L = 48,9

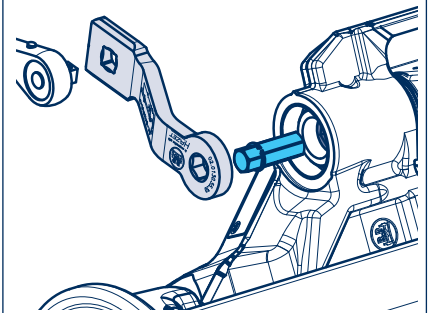
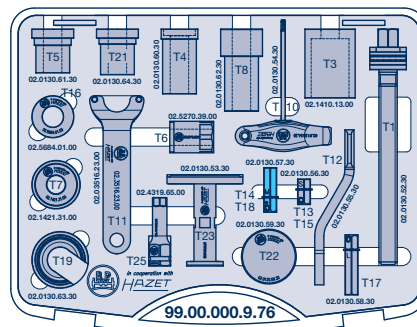

T16

Ring (Ring zum Einziehen der Radbolzen) /
Ring (Ring for pulling in wheel studs) /
Anneau (Bague pour mise en place des
goujons de roue)

02.5684.01.00 Ø 23 / 46 x 15

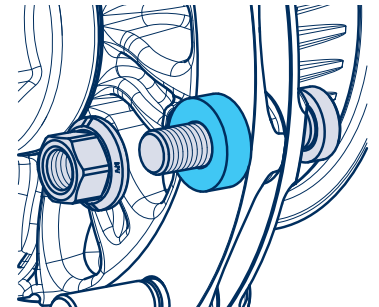
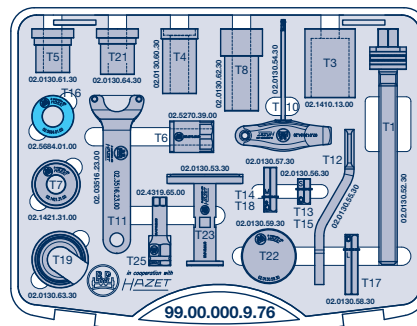

T17

Klinge für Schlagschlüssel - Größe L /
Blade for impact spanner - size L /
Lame pour clé à chocs - Taille L

02.0130.58.30 SW 14 / L = 65,9

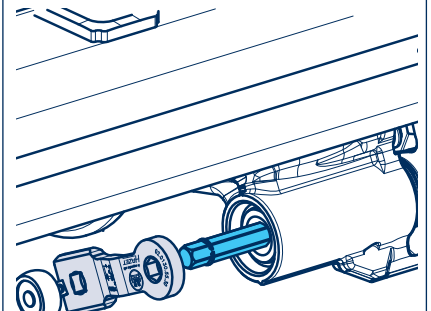
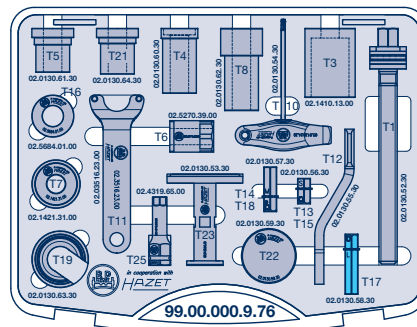

T19 (TSB)

Montagewerkzeug für Faltenbalg /
Mounting tool for the bellows /
Outil de montage pour soufflet

02.0130.63.30 Ø 27,6 / 62 x 32

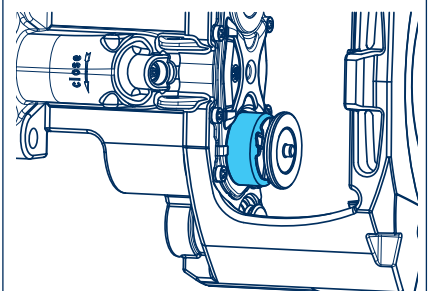
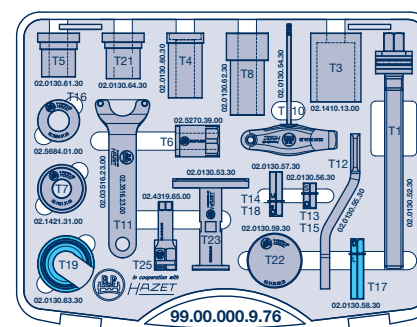

Spezialwerkzeuge / Special tools / Outil spécial

T21 (TS2)

Einpresswerkzeug Loslager /
Pressing tool movable bearing /
Outil d'emmanchement (palier libre)

02.0130.64.30 Ø 20,5 / 45,8 x 50

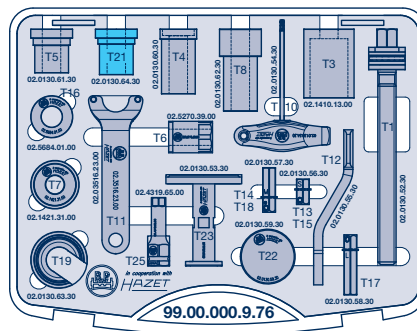

Anwendung siehe Seite 12 - 15 /
Application see page 12 - 15 /
Application voir page 12 - 15

T22 (TS2)

Glocke für Einpresswerkzeuge
Faltenbalg /
Piston for pressing tool bellows /
Piston pour outil d'emmanchement pour
soufflet

02.0130.59.30 Ø 60 x 35 / M 10

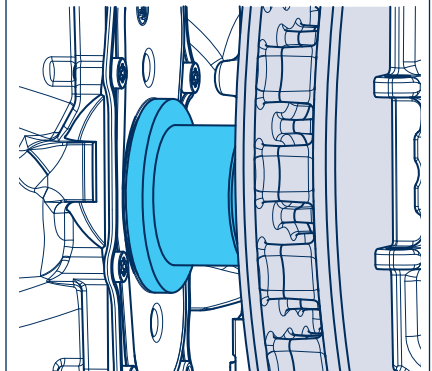
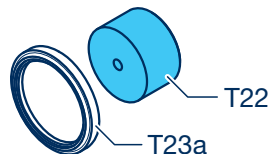
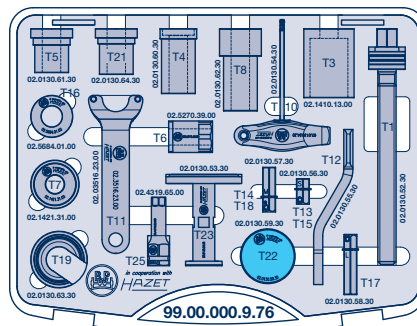

T23 (TS2)

Einpresswerkzeug für Faltenbalg /
Pressing tool for bellows /
Outil d'emmanchement pour soufflet

02.0130.53.30 Ø 40 / Ø 83 x 120 /
SW 21

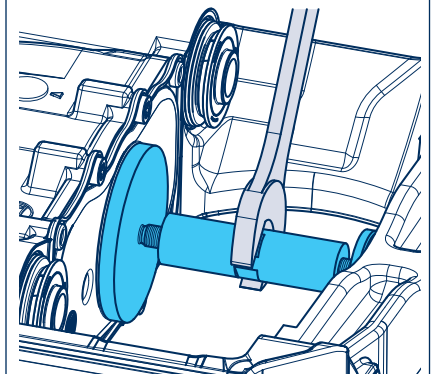
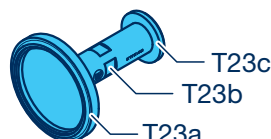
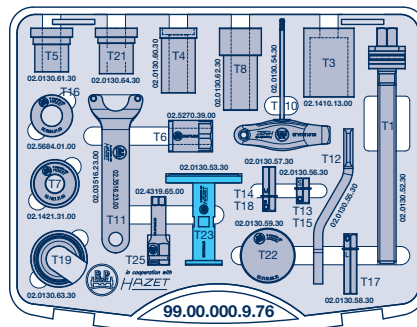

Spezialwerkzeuge / Special tools / Outil spécial

T25

Schlag- und Maschinenschraubereinsatz /
Impact and machine screwdriver insert /
Visseuse à percussion et visseuse
mécanique

02.4319.65.00 SW 14 / SW 24 x 75 /
1/2"

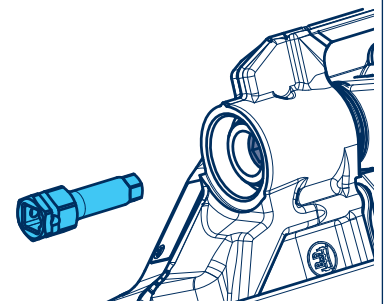
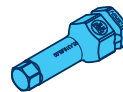
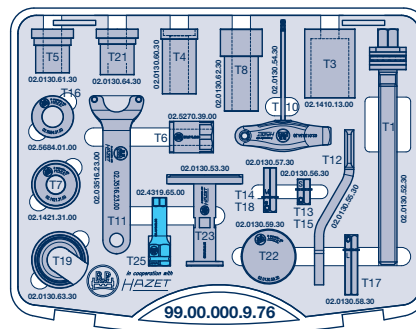

Auspresswerkzeug für Loslager / Press-out tool for movable bearing / Extrakteur de palier libre

Pos. / item / rep. T1, T3, T4, T6

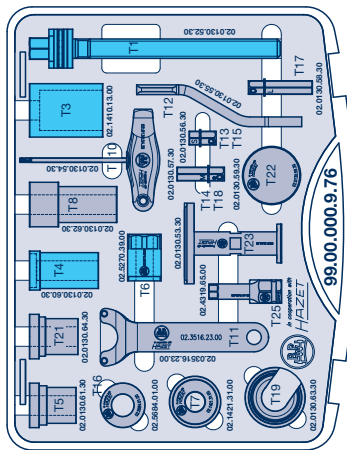

Max. Anziehdrehmoment: 300 Nm
Keinen Schlagschrauber verwenden!
 Max. Tightening torque: 300 Nm
Do not use an impact wrench!
 Couple de serrage max. : 300 Nm
Ne pas utiliser de visseuse à choc !

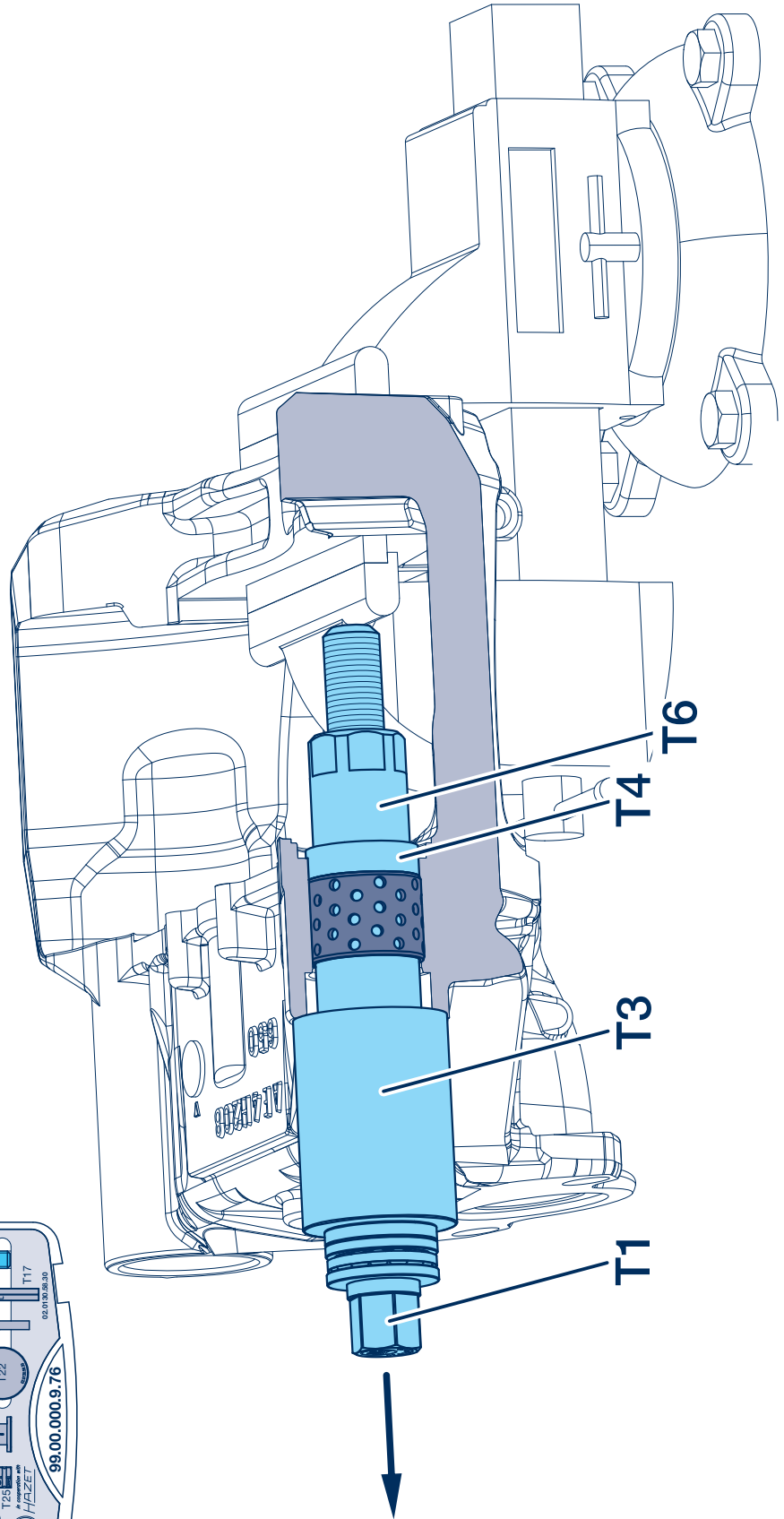

Einpresswerkzeug für Loslager / Pressing tool for movable bearing / Outil d'emmanchement pour palier libre

Pos. / item / rep. T1, T4, T5, T6, T7/T20 (TSB)

Pos. / item / rep. T1, T4, T21, T6, T7/T20 (TS2)

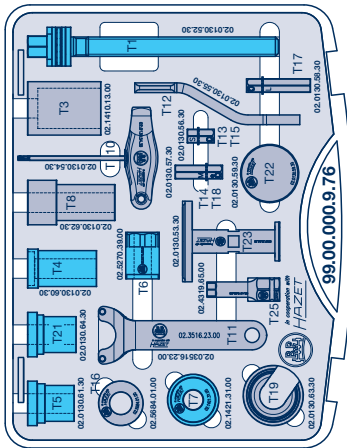

Max. Anziehdrehmoment: 300 Nm
Keinen Schlagschrauber verwenden!
Max. Tightening torque: 300 Nm
Do not use an impact wrench!
Couple de serrage max. : 300 Nm
Ne pas utiliser de visseuse à choc !

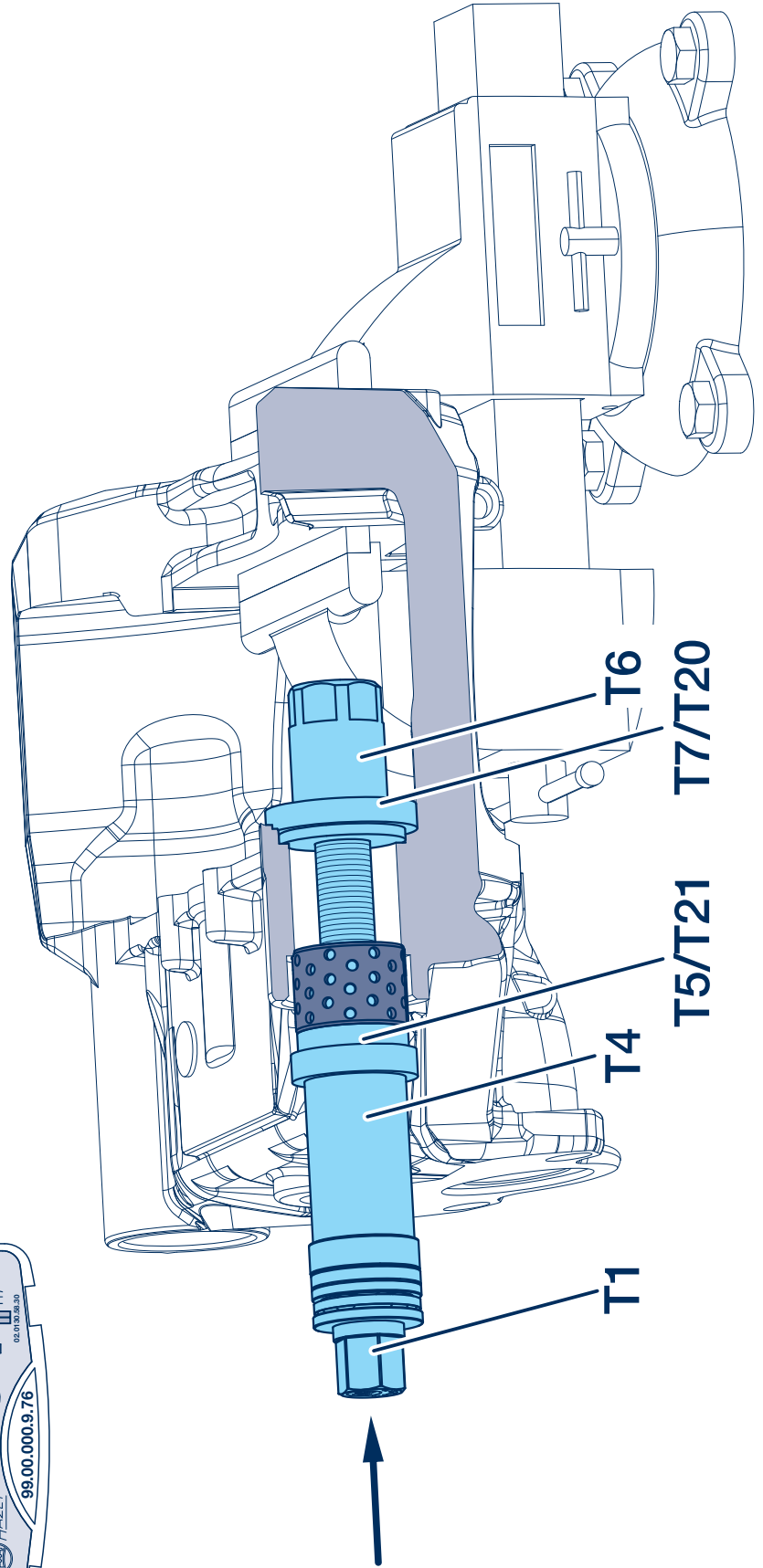

Spezialwerkzeuge / Special tools / Outil spécial

Auspresswerkzeug für Festlager / Press-out tool for fixed bearing / Extracteur de palier fixe

Pos. / item / rep. T1, T3, T4, T6

Max. Anziehdrehmoment: 300 Nm
Keinen Schlagschrauber verwenden!
 Max. Tightening torque: 300 Nm
Do not use an impact wrench!
 Couple de serrage max. : 300 Nm
Ne pas utiliser de visseuse à choc !

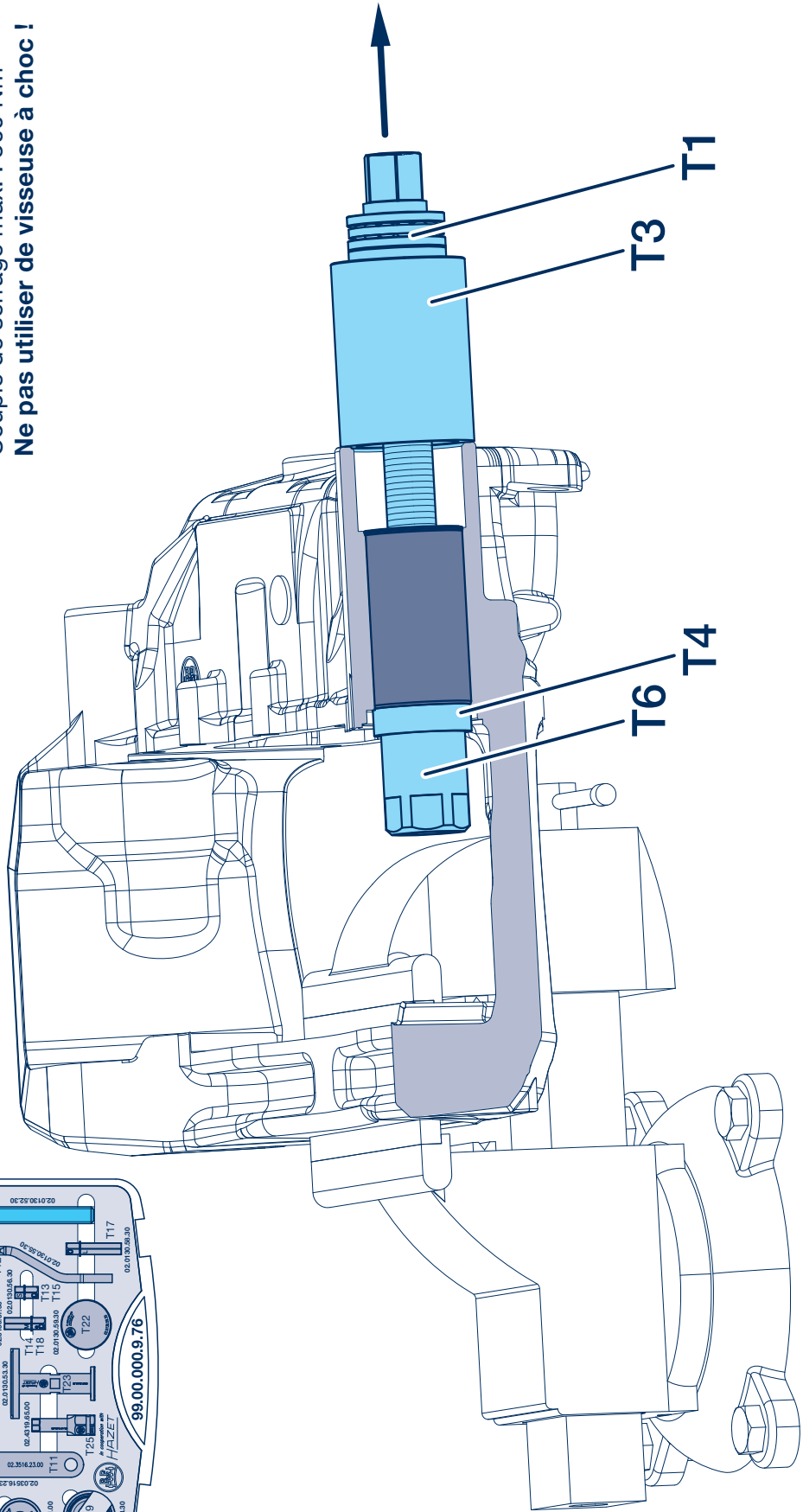
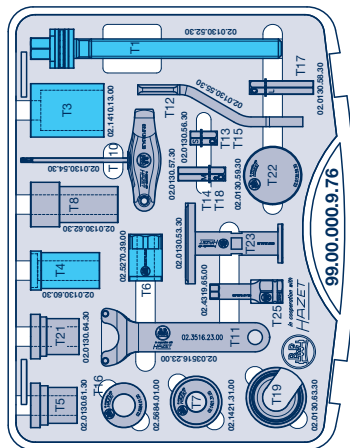

Spezialwerkzeuge / Special tools / Outil spécial

Einpresswerkzeug für Festlager / Pressing tool for fixed bearing / Outil d'emmanchement pour palier fixe

Pos. / item / rep. T1, T6, T7/T20, T8

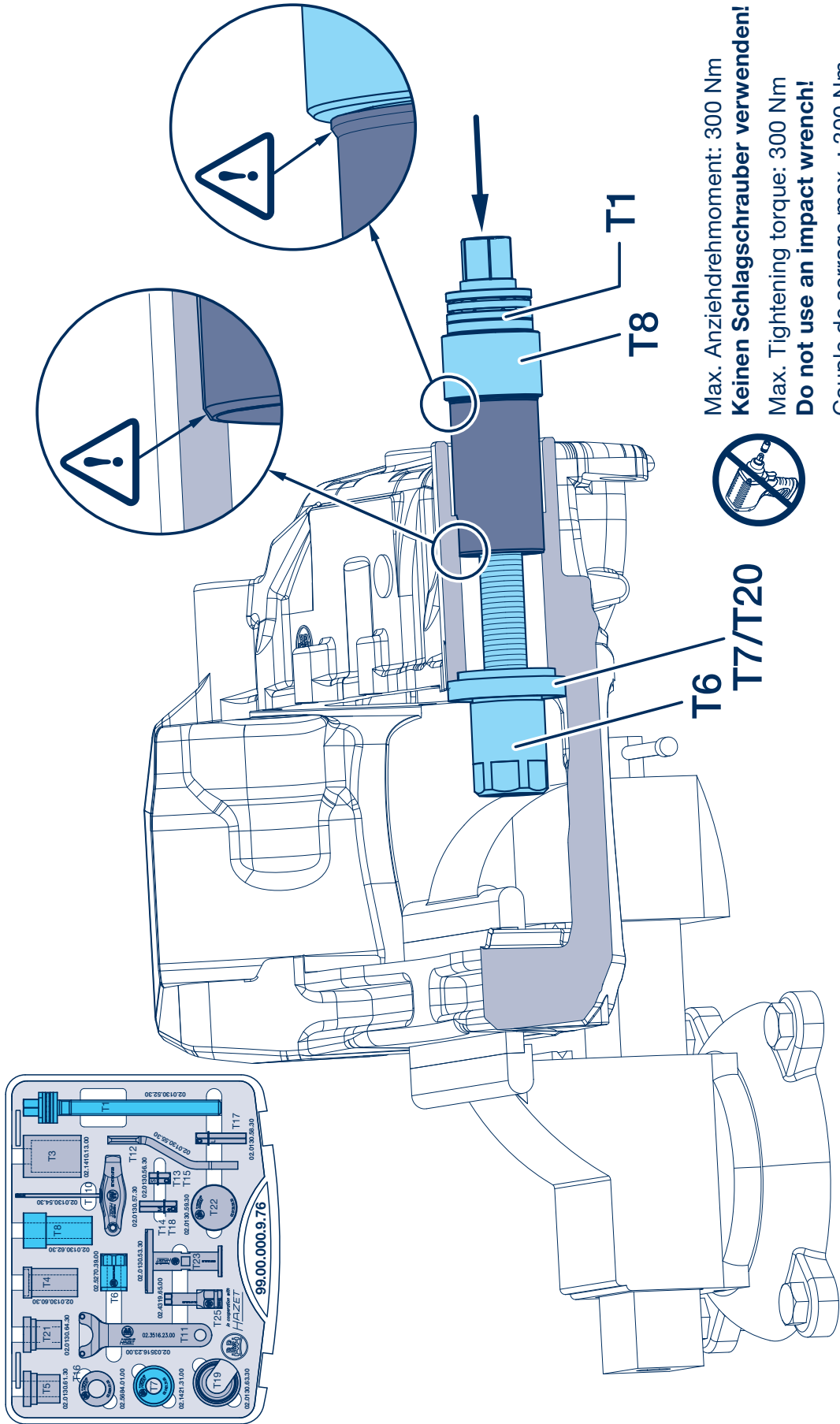

Max. Anziehdrehmoment: 300 Nm
Keinen Schlagschrauber verwenden!



Max. Tightening torque: 300 Nm
Do not use an impact wrench!

Couple de serrage max. : 300 Nm
Ne pas utiliser de visseuse à choc !



BPW WK-39602401 def 04.001.21.51.0 V0



BPW Bergische Achsen Kommanditgesellschaft

Postfach 12 80 · 51656 Wiehl, Deutschland · Telefon +49 (0) 2262 78-0
info@bpw.de · www.bpw.de